

**DC PORTABLE ASPIRATOR  
OPERATION/SERVICE MANUAL**

**Allied**  
**HEALTHCARE PRODUCTS INC.**

1720 SUBLETTE AVE. ST. LOUIS, MO 63110

**DC MODELS:**

**L190/L190CE: EMERGENCY PORTABLE SUCTION UNIT, HI – LOW CONTROLS, W/ DOCKING STATION ADAPTER**

**L190-GR/L190-GRCE: EMERGENCY PORTABLE SUCTION UNIT, GAUGE AND REGULATOR, W/ DOCKING STATION ADAPTER**

**G180/G180CE: GOMCO PORTABLE ASPIRATOR, GAUGE & REGULATOR**

**FOREIGN LANGUAGE MANUAL: SEE S168-507-001-X FOR FRENCH, GERMAN, AND SPANISH**



## SYMBOL DEFINITIONS:



READ



“OFF” (only for a part of EQUIPMENT)



“ON” (only for a part of EQUIPMENT)

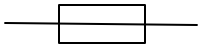

FUSE



INCREASE (CLOCKWISE)

DECREASE (COUNTER CLOCKWISE)

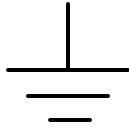

PROTECTIVE EARTH (GROUND)



ALTERNATING CURRENT



DIRECT CURRENT



TYPE B EQUIPMENT



**WARNING: READ THIS ENTIRE MANUAL BEFORE USING ASPIRATOR.**



**WARNING:** Federal law restricts this device to sale by or on the order of a physician.

## GENERAL INFORMATION:

### **Purpose:**

The Portable Suction Unit is designed to provide general suction.

### **Bacteria Filter:**

The high efficiency bacteria filter is custom engineered to prevent fluid and aerosol contamination of mobile and portable suction units. This filter features a hydrophobic, microporous membrane, which filters air with maximum efficiency (0.3 micron particles in air), while blocking the flow of aqueous fluids and aerosol contaminants. The Allied high efficiency filter protects the suction pump from canister overflow.

### **Operating Principle**

The reciprocating motion of the diaphragm inside the pump head develops the negative and positive pressures of a diaphragm pump. These pressures are maintained by the motion of the piston and the pressure and suction flapper valves. On the up-stroke, the pressure valve will open to allow air flow through the exhaust or pressure port. On the down stroke the pressure valve closes and the suction valve opens which draws a vacuum, or creates a negative pressure, at the suction side.

## 1.0 SPECIFICATIONS:

### **1.1 Vacuum Range:**

L190: 4.9 to 21.6 in Hg. (125 mm Hg and 550 mm Hg) @ STP.

L190-GR & G180: 2.0 to 21.6 in Hg. (25 mm Hg to 550 mm Hg.) @ STP.

### **1.2 Flow Rates:**

Open flow > 30 LPM @ STP.

### **1.3 Electrical Requirements:**

Charging: 12.0 – 16.0 VDC, 1.0A max.

Operating: 12.0 – 16.0 VDC, 3.4A max.

AC Power Supply: 115 VAC 50/60 Hz., 1.8 A max. – 230 VAC 50/60 Hz., 0.9 A max.

### **1.4 Motor & Pump Description:**

DC, 1/32th H.P. Permanent Magnet, single cylinder oil-less diaphragm pump.

### **1.5 Dimensions:**

- a. L190 & L190-GR:  
7.5" (W) X 10.6" (L) X 9.4" (H) (15.5" (L) to end of DCU Holder)
- b. G180  
6.8" (W) X 10.6" (L) X 9.4" (H) (16.8" (L) to end of DCU Holder)

### **1.6 Weight**

- a. L190 & L190-GR: 10.6 lbs.
- b. G180: 11.4 LBS.

### **1.7 Operating Time:**

- a. L190 & L190-GR: 75 minutes @ max. load
- b. G180: 180 minutes @ max. load

### **1.8 Recharge time (DC unit):**

L190 & L190-GR: 6 hours.

G180:8 hours.

### **1.9 Battery type (DC unit):**

Sealed lead – acid, rechargeable.

### **1.10 Environmental Conditions:**

- a. Operating Temperature: -4 °F to 120 °F  
Operating Relative Humidity: 10% to 95% Non Condensing
- b. Storage & Transport Temperature: -40 °F to 140 °F  
Storage & Transport Relative Humidity: 10% to 95% Non Condensing  
Storage & Transport Pressure: 1 ATM ± .5 ATM

### **1.11 Electromagnetic Interference:**

Classified per UL 60601-1. This unit is not MRI compatible.

## 2.0 SET-UP

### 2.1 Disposable Collection Container

1. Snap the lid onto the container firmly.
2. Insert the container into the canister ring and seat firmly.
3. Connect the 72" length of tubing to the 90 degree tubing connector in the lid marked "PATIENT"
4. Connect the 8" length of tubing to the vertical connector on lid marked "VACUUM".
5. The bacteria filter may now be placed in-line by cutting the 8" length of tubing in half and inserting the barbed fittings into hose ends, making sure that the side marked "FLUID SIDE" is toward the container.
6. Connect the remaining end of the length of tubing to the short vacuum inlet on top of housing.

### 2.2 1200 mL Collection Container (Glass or Polycarbonate)

1. The bottle and cap assembly should be sterilized prior to use.
2. Check that the cap gasket is properly positioned inside the cap cover and that the gasket seals. Check that the float moves freely.
3. Place the bottle in the bottle holder of the unit.
4. Connect the 72" length of clear tubing to the collection bottle stem marked "To Patient".
5. Connect the 13" length of clear tubing to the collection bottle stem marked " Vacuum Source".
6. The bacteria filter may now be placed in-line by cutting the 13" length of tubing in half and inserting the barbed fittings into hose ends, making sure that the side marked "FLUID SIDE" is toward the container.\*
7. Connect the remaining end of the length of tubing to the short vacuum inlet on top of housing.

### 2.3 Activate Battery Connection

The aspirator is shipped with the battery disconnected to prevent the battery from becoming discharged during storage. To connect the battery, the fuse that is attached to the outside of the aspirator must be installed. Place the fuse into the fuse holder located on the back of the unit above the AC power connection. Use a flat blade screwdriver and rotate the fuse holder clockwise approximately 1/8 turn to lock in place. Connect the unit to one of the approved power sources and allow to fully charge.

## 3.0 OPERATING PROCEDURE



**WARNING: Do not use in the presence of flammable anesthetics.**

- 3.1 Activate unit from one of the three power sources listed:
  - 115 or 230 Volt AC line current
  - Internal rechargeable battery
  - External 12 Volt DC automotive supply
- 3.2 Press power switch "I" to turn unit on and "O" to turn it off.
- 3.3 To check the degree of vacuum for the L190-GR unit (with gauge and a regulator), do the following:
  - a. Pinch off the patient tube. The amount of vacuum, in millimeters of mercury (mm Hg), will register on the vacuum gauge.
  - b. Increase the vacuum by turning the regulating knob clockwise. To decrease the vacuum, turn the knob counter-clockwise.
  - c. Release the pinched tubing.
- 3.4 For the L190 unit, press the "Hi vacuum" switch to select the high vacuum level. Press the "Lo vacuum" switch to select the low vacuum level.
- 3.5 The battery will recharge, from a condition of low charge, within 8 hours maximum, using either the external 12 Volt DC or 115 or 230 Volt AC power supplies when the unit is idle. When battery is fully charged, charging is automatically stopped and battery is maintained at full charge if charger is connected.\*
- 3.6 When the unit is on, is being charged, or testing battery status (pushing "off" button), the LED's indicate the

state of the battery as follows:

- Five green LED's indicate a fully charged battery condition.
- Four/three green LED's indicate a normal battery condition, but not fully charged.
- Two red LED's indicate a drained battery condition with limited run time.
- One red LED indicates a drained battery condition, unit will shut down soon.
- Five red LED's, **during charging only**, indicate the battery needs to be replaced.

\* The battery should be recharged every two weeks even if it hasn't been used. To store the aspirator for periods of time longer than one month, the battery connection fuse (sec. 2.3) should be removed.

**For optimum battery performance the unit may be left plugged in at all times. The unit will turn the charging circuit "On & Off" to keep the battery at a full charge level.**

## 4.0 MAINTENANCE AND SERVICE



**WARNING: Electric shock hazard. Refer servicing to qualified service personnel.**

### 4.1 PUMP LUBRICATION:

The pump and motor are permanently lubricated and require no oiling or greasing.



**CAUTION: Do not at any time lubricate any of the parts with oil, grease or petroleum products.**

### 4.2 BACTERIA FILTER

The Bacteria Filter should be replaced after one month of patient use or when a reduction of air flow is noticed. With the vacuum regulator fully closed and the tubing disconnected from the "Fluid Side" of the filter (filter open to atmosphere), a vacuum reading in excess of 50 mm Hg on the gauge indicates the filter should be replaced. **It must be replaced** in the event fluids have been in contact with the filter, such as in a collection bottle overflow.

**NOTE:** Extended use of alcohol or solvents may reduce the hydrophobic properties of the microporous membrane.



**WARNING: Treat the bacteria filter, tubing & drainage fluids as biohazard materials**

### 4.3 TUBING:

The tubing must be changed after each patient.

### 4.4 BACTERIA FILTER, TUBING & COLLECTION BOTTLE DISPOSAL:

Dispose of in accordance with state and local codes for biohazard materials.

### 4.5 TO REMOVE CASE TOP FROM CASE BOTTOM:

1. Always disconnect any power source.
2. Remove the screws from the sides and back of the unit.
3. Remove the Case Back from the Case Front and lay along side the Case Bottom.
4. Disconnect the ground wire from the bulkhead assembly.
5. Disconnect the tubing connecting the bulkhead fitting assembly to the vacuum pump.
6. Remove the Case Front and lay along side the Case Bottom.
7. Disconnect the Wiring Harness from the PC Board
8. Disconnect the wires from the IEC Connector
9. If the unit contains a Docking Station Charger disconnect the wire from the Docking Station to the Power Supply.
10. Reassemble in reverse order.

#### **4.6 BATTERY REPLACEMENT:**

1. Remove the Case Back and Case Front from the case Bottom.
2. Remove the gray wire connection from the battery (+). Remove the black wire connection from the battery (-)
3. Remove the three screws that attach the battery hold down bracket to the Case Bottom.
4. Remove the battery hold down bracket.
5. Lift up and remove the battery carefully.
6. Install new battery, secure with the battery hold down bracket and associated screws and complete the wire connections: gray wire to the battery (+) & black wire to the battery (-).
7. Check unit for proper operation.
8. Discard old battery per local ordinances.

#### **4.7 FUSE REPLACEMENT:**

1. Two 4 amp fuses located inside the power entry fuse drawer on the rear of the unit.
2. Pull fuses out of drawer and replace only with a fuse of equal size and rating (4 amp, 250V).
3. Replace the fuse drawer into the power entry.
4. There is a 10 amp, 250V slow blow fuse located in the fuse holder above the power entry. To replace, use a flat blade screwdriver to rotate the fuse holder cap 1/8 turn counter-clockwise and replace the fuse with one of equal size and rating.



**WARNING:** To help prevent fire/shock hazard, replace only with a fuse of equal size and rating.

#### **4.8 PUMP REPLACEMENT:**

1. Remove the Case Back and Case Front from the Case Bottom.
2. Disconnect the black and red wires leading from the pump to the wire harness connections.
3. Remove the battery bracket.
4. Remove the three screws and one standoff that attach the Mounting Plate Assembly to the Case Bottom.
5. Lift up and remove the Mounting Plate Assembly from the Case Bottom.
6. Remove the tubing and barbed fitting from the vacuum pump inlet and outlet ports.
7. Remove the screws and washers that attach the pump to the mounting plate. These are located underneath the mounting plate.
8. Remove pump.
9. Reassemble in reverse order.

#### **4.9 PC BOARD REPLACEMENT:**

1. Remove the Case Back and Case Top from the Case Bottom.
2. Disconnect the Wire Assembly from the connector on the back of the PC Board.
3. Unscrew the screws that attach the PC Board to the Case Top.
4. Remove the PC Board.
5. Reassemble in reverse order.

#### **4.10 SOLENOID REPLACEMENT:**

1. Remove the Case Back and Case Front from the Case Bottom.
2. Disconnect solenoid wire from the battery (+).
3. Disconnect the solenoid wire from the purple wire of the Wire Harness Assembly.
4. Remove the screws that attach the Mounting Plate Assembly to the Case Bottom.
5. Lift up and remove the Mounting Plate Assembly from the Case Bottom.
6. Disconnect the tube that connects to the solenoid inlet port.
7. Remove the fitting from the solenoid inlet port.
8. Remove the screws and washers that attach the solenoid to the mounting plate.
9. Remove the solenoid.
10. Reassemble in reverse order.

#### **4.11 POWER SUPPLY REPLACEMENT:**

1. Remove the Case Back and Case Front from the Case Bottom.
2. Remove the three screws that attach the battery hold down bracket to the Case Bottom.
3. Remove the battery hold down bracket.
4. Remove the Power Supply from the Case Bottom.
5. Disconnect the Wire Assemblies from the Power Supply.
6. Reassemble in reverse order.

#### 4.12 VACUUM GAUGE REPLACEMENT:

1. Remove the Case Front from the Case Bottom.
2. Disconnect the tubing connecting the regulator elbow fitting to the bulkhead fitting assembly.
3. Remove the regulator knob by loosening the two set screws. Note: Do not remove screws from the knob.
4. Remove the regulator hex cap by unscrewing from the regulator body.
5. Remove the regulator and gauge assembly from the Front Case.
6. Remove the gauge.
7. Assemble new gauge with its face oriented parallel to the Front Case control panel surface.
8. Reassemble in reverse order.

#### 4.13 VACUUM REGULATOR REPLACEMENT:

1. Remove the regulator and gauge assembly.
2. Remove the gauge and elbow fitting.
3. Replace Regulator Body and Needle Valve with parts from replacement kit..
4. Reassemble in reverse order.

#### 4.14 ENCLOSURE CLEANING:

1. Should the enclosure require cleaning, first remove the power cord from the IEC Connector.
2. The Enclosure may be cleaned with a slightly damp cloth.
3. The cloth may contain a mild solution of soap and water.
4. Remove traces of soap with a damp cloth that has been soaked in water.
5. After cleaning, wipe the unit dry.

#### 4.15 STERILIZATION OF CAP AND 1200 ml GLASS JAR:

1. Remove the cap assembly from the bottle.
2. Dispose of drainage fluids and materials in the bottle (Per local regulations).
3. Soak the bottle and cap assembly in a warm detergent solution. Wash all the parts with a nylon bristle brush, rinse thoroughly with water and aerate.
4. Autoclave at 250 °F (121 °C) for 15 minutes following the autoclave manufacturer's recommended procedure.



**CAUTION: Do not flash autoclave the glass collection bottle. If desired, sterilize with ethylene oxide gas. Following manufacturer's directions for recommended procedure.**

#### 4.16 STERILIZATION OF CAP AND 1200 ml POLYCARBONATE JAR:

1. Remove the cap assembly from the bottle.
2. Dispose of drainage fluids and materials in the bottle (Per local regulations).
3. Soak the bottle and cap assembly in a warm detergent solution (any mild non-alkaline). Wash all the parts, rinse thoroughly with water and aerate.
4. Autoclave at 250 °F (121 °C) for 15 minutes following the autoclave manufacturer's recommended procedure. Do not exceed 270 °F (132 °C).



**Warning: Do not use abrasives such as scouring powders, steel wool, alkaline detergents or cleaning agents not compatible with polycarbonate material.**

**NOTE:** If further technical assistance is needed, please contact our service center at the address listed below:

**Allied Healthcare Products, Inc. Service Center**  
1720 Sublette Avenue  
St. Louis, Missouri 63110-1968 U.S.A.

**Telephone: (800) 411-5136**  
**Fax: (314) 771-6341**

## 5.0 WARRANTY INFORMATION

**LIMITED WARRANTY:** Allied warrants for a period of one year for the L190 & L190-GR units and one year for the battery, three years for the G180 unit and one year for the battery, from date of shipment that the products manufactured by Allied are free from defects in material and workmanship. Allied makes no warranty with respect to products manufactured by others and furnished hereunder, provided, however, Allied shall extend to Buyer any warranties which it received from such vendors. Items for repair under warranty will be covered for parts by Allied, when returned prepaid to Allied's Repair Department. Labor and travel will be charged to the Buyer for repairs made outside Allied's Repair Department.

In the event of breach of any warranty hereunder, Allied's sole and exclusive liability shall be its option either to repair or replace F.O.B. destination any defective products, or to accept return of such product and refund the purchase price; in either case provided that written notice of such defect is given to Allied within warranty period of product purchased, that the product is found by Allied to have been defective at the time of such shipment, that the product has been installed and/or operated in accordance with Allied's instructions, that no repairs, alterations or replacements have been made by others without Allied's written approval, and that Buyer notifies Allied in writing within forty-five (45) days after the defect becomes apparent and promptly furnishes full particulars in connection therewith, and provided further that in no event shall the aggregate liability of Allied in connection with breach of any warranty or warranties exceed the purchase price paid for the product purchased hereunder. Allied may, at its option, require the return of any product, transportation and duties prepaid, to establish any claim of defect made by Buyer. Allied will not accept and shall have no responsibility for products returned without its prior written consent and Allied will not assume any expense or liability for repairs to products. In the event Allied elects to replace a defective product, costs of installation, labor, service and all other costs to replace the product shall be the responsibility of Buyer. **EXCEPT AS EXPRESSLY STATED HEREIN, ALLIED MAKES NO WARRANTIES, EXPRESSED OR IMPLIED, AND DOES NOT WARRANT THAT THE PRODUCTS ARE MERCHANTABLE OR FIT FOR ANY PARTICULAR PURPOSE.**

Allied shall not, except as set forth above, be otherwise liable to Buyer or to any person who shall purchase from Buyer, or use, any product supplied hereunder for damages of any kind, including, but not limited to direct, indirect, special or consequential damages or loss of production or loss of profits resulting from any cause whatsoever, including, but not limited to, any delay, act, error or omission of Allied.

Every claim from any cause shall be deemed waived by Buyer unless made, in writing, within twelve (12) months of the receipt by Buyer of the goods to which such claim relates. No legal proceedings will be brought for any breach of this contract more than one year after the occurrence of the cause of action.



**PNEUMATIC SCHEMATIC #1: DC, EMERGENCY PORTABLE SUCTION UNIT**

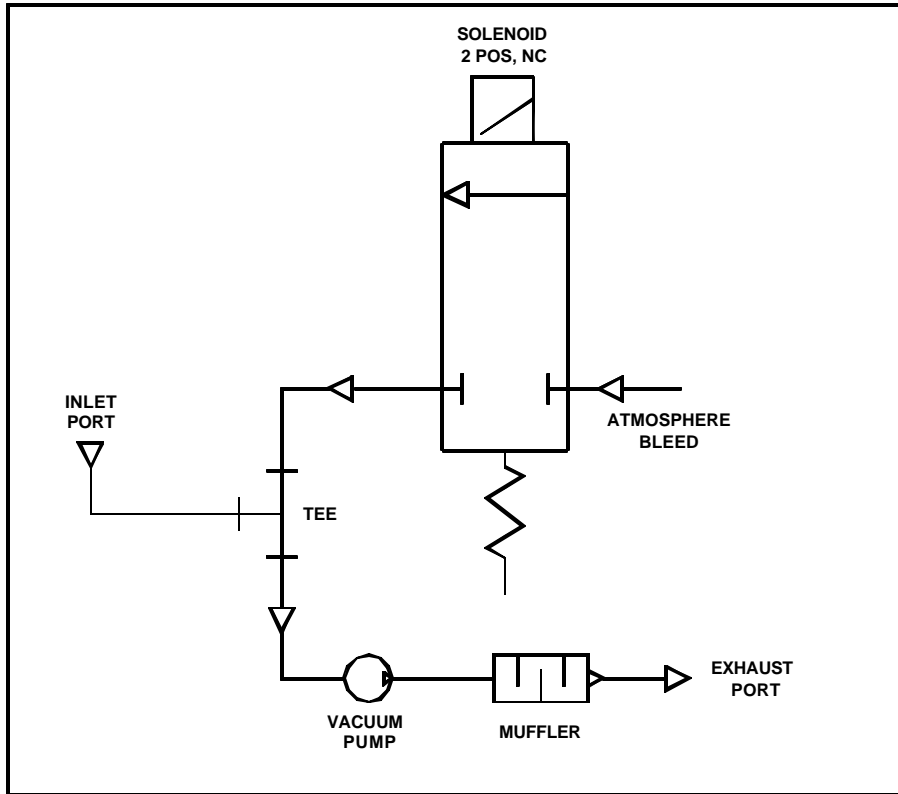

**PNEUMATIC SCHEMATIC #2: DC, REGULATED**

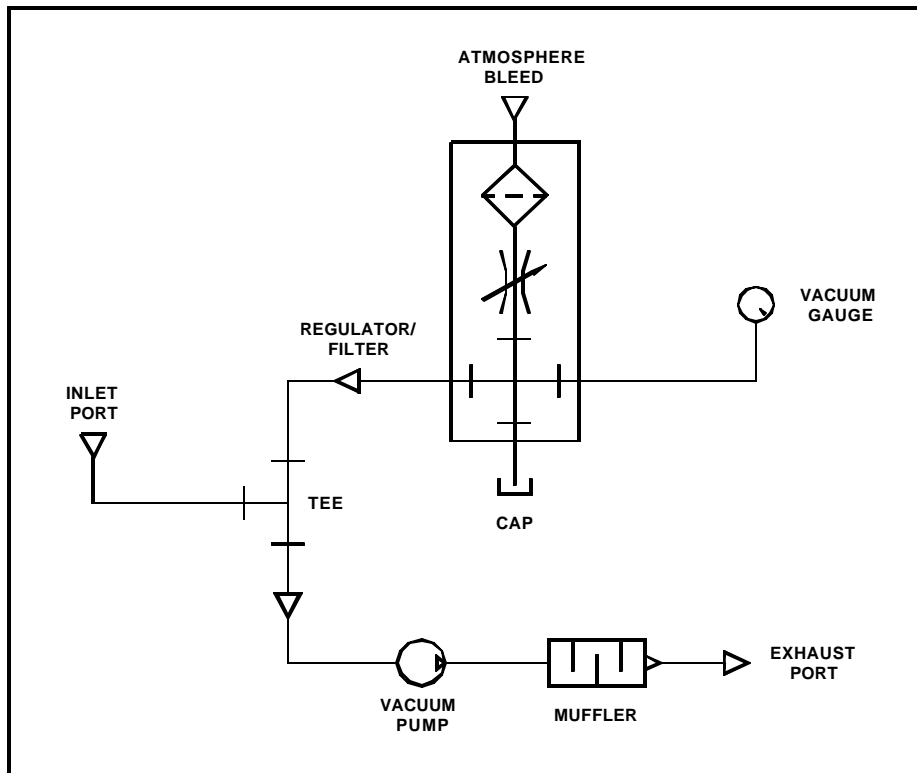

## ELECTRICAL SCHEMATIC #1: DC, EMERGENCY PORTABLE SUCTION UNIT

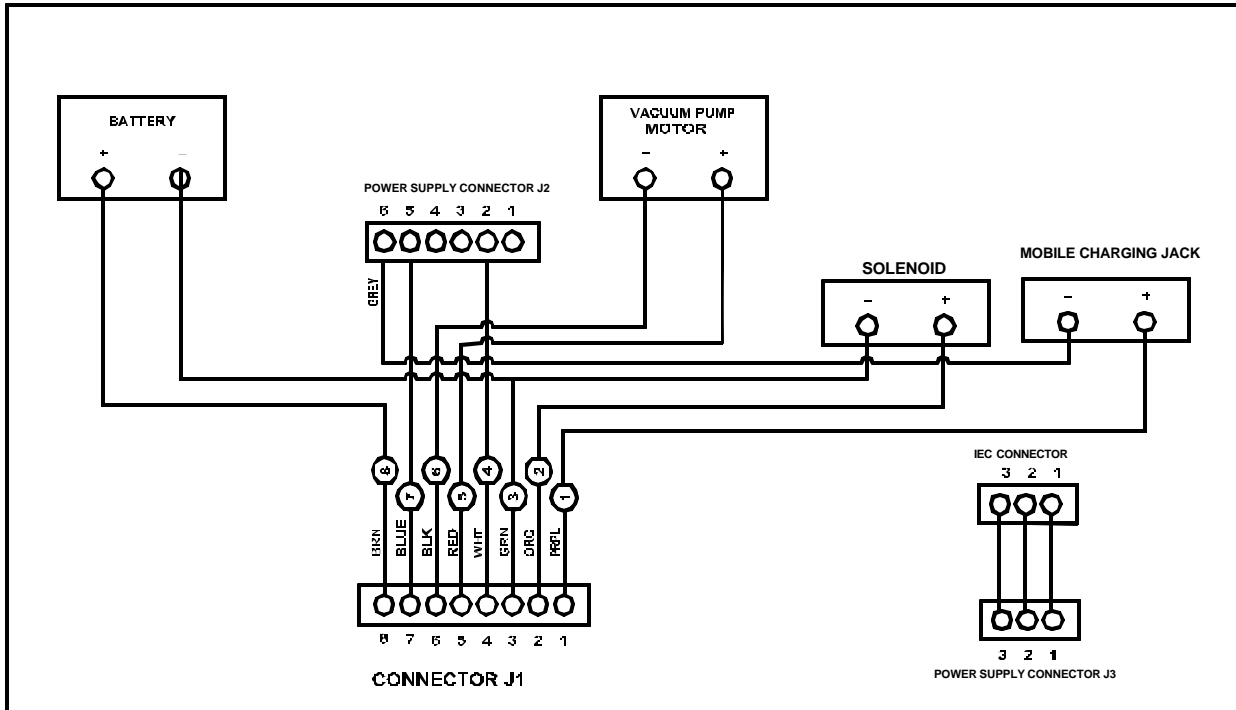

## 6.0 TROUBLESHOOTING :

PROBLEM	CAUSE	SOLUTION
Pump will not run when switch is pushed "ON"	Bad fuse	Replace fuse (see Sect. 4.7)
	Overheated pump due to extended operation with obstructed output	Let cool and remove obstruction
	Defective Pump	Replace pump (see Sect. 4.8)
Low Suction	Loose bottle cap or tubing connection	Check all connections Tighten cap (AC)
	Vacuum line cracked, leaking	Replace the vacuum line
	Bacteria filter is clogged	Replace filter
	Vacuum regulator is leaking (for Gauge/Regulator versions)	Clean or replace needle
Pump runs, but no suction	Disconnected vacuum lines	Check all tubing
	Bacteria filter is clogged	Replace filter
	Pump defective	Replace pump (see Sect. 4.8)
	Collection unit is full	Replace collection unit (DC) Empty or replace collection unit (AC)
5 Red LEDs when charging	Battery is bad	Turn unit on and off and let charge for 8 hours. If light continues to flash replace battery (see Sect. 4.6)

## 7.0 REPLACEMENT PARTS LIST

CAT. NO	Description
L200001	Regulator Assembly
L200002	Control Panel Overlay, DC, Emergency, Hi/Lo
L200003	Control Panel Overlay, DC, Emergency Gauge and Regulator
L200004	Control Panel Overlay, DC, Gomco Gauge and Regulator
L200005	Bulkhead Fitting
L200006	Tubing, 1/4" ID X 1/2" OD, Non-Conductive
L200007	Control Board – DC, Regulated
L200008	Control Board – DC, Hi-Lo Vacuum
L200009	Wire Harness Assembly, DC
L200011	Tubing, 3/8" ID X 1/2" OD, Non-Conductive
L200012	Solenoid Valve, 2 POS, NC
L200014	IEC Connector
L200015	Feet, Rubber
L200017	Vacuum Gauge, 2" Dia. Face
L200018	Power Supply 115 Volts
L200019	Pump, DC
L200021	Knob, Soft Touch, Regulator
L200022	Fuse Kit – DC
L200023	AC Power Cord, Emergency
L200024	Screw Kit
L200025	AC Power Cord, Gomco With Hospital Grade Plug
L200027	Battery, 12VDC, 3.4 Amp-hr
L200029	Bracket, 1500 mL DCU
L200030	Bracket, 800 mL DCU
L200032	Fuse & Cap Kit
L200033	Power Supply 230 Volts
SU1060	Battery, 12VDC, 5.0 Amp-hr

## 8.0 ACCESSORY PARTS LIST

CAT. NO	Description
01-90-3928	Bacteria Filter, 1/4 X 1/4 Barb, 3/Pkg.
01-90-3928-KIT	Bacteria Filter, Case of 30 (3/Pkg.; 10 Pkgs/Case)
20-08-0003	1500 mL Disposable Collection Canister (case of 48)
01-90-3489	1200 mL Collection Container (Glass) With Cap & Float Assy.
22-10-4002	1200 mL Collection Container (Polycarbonate) With Cap & Float Assy
20-08-0016	1500 mL Disposable Collection Canister (Case of 16)
L190-BAG	Bag, Case with Shoulder Strap
L200-010	Docking Station Kit.
L200031	Tubing Kit (8" & 72")
S1160-RP1	800 mL Disposable Collection Canister (Case of 5)



**1720 Sublette Avenue  
St. Louis, Mo. 63110  
Telephone: (314) 771-2400  
Toll Free: (800) 444-3954**

***INSTRUMENTS OF CARE***

FORM NO. S168-507-001 Rev. H  
**Allied Healthcare Products Inc.**  
(DC)

AUTHORIZED EU REPRESENTATIVE  
MEDIZINTECHNIK & CONSULTING  
EFFENGRUBE 14  
23552 LUBECK, GERMANY  
TEL: +49-451-8090-4200 FAX: +49-451-8090-4231

